



# Haiku® Fans I Series

## What a Smart Ass™ Fan

The I Series ceiling fan embodies our dedication to design, simplicity and efficiency. Built from our durable matrix glass composite and coated with three layers of automotive-quality paint, I Series is as resilient as it is sleek. Onboard SenseME™ Technology allows for automated fan operation, tailoring it

to fit your unique comfort needs and maximize both comfort and conservation. I Series exceeds ENERGY STAR® standards by up to 750% and is capable of connecting with other smart technologies to significantly reduce the workload of heating and cooling systems.

### SenseME Technology Features



#### Motion Sensor

Detects when you enter or leave a room, turning the fan and LED light on and off automatically



#### Whoosh® Mode

Silently varies fan speed to mimic cooling natural breezes



#### Smart Mode

Alternates between seasonal settings—Smarter Heating and Smarter Cooling—to maintain comfort and maximize energy savings



#### Sleep Mode

Responds to changing conditions to provide customized comfort all night long



#### Scheduling

Sets precise schedules for fan control modes



#### Wi-Fi

Connects to the Haiku Home mobile app for fan control and over-the-air updates

# I Series Fans

## TECHNICAL SPECIFICATIONS

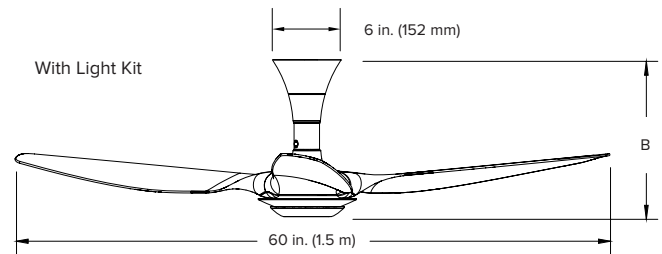
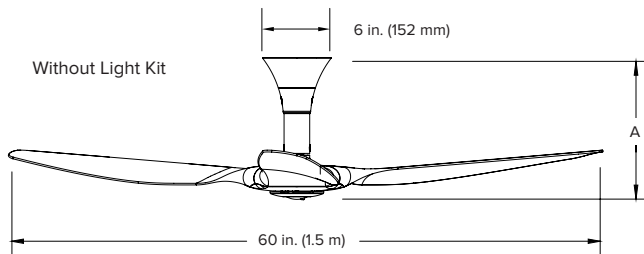

### Technical Specifications

<b>Model</b>	I Series Low Profile Mount	
<b>Model number<sup>1</sup></b>	K3150-S0-XX-XX-02-C	
<b>Fan diameter</b>	60 in. (1.5 m)	
<b>Fan height without light (A)</b>	12 in. (305 mm)	
<b>Fan height with light (B)</b>	12.5 in. (318 mm)	
<b>Hanging weight<sup>2</sup></b>	16 lb (7.3 kg)	
<b>Motor and assembly finishes</b>	Black or white	
<b>Airfoil material</b>	Glass Composite	
<b>Airfoil finishes</b>	Black or White	
<b>Number of airfoils</b>	3	
<b>Motor type</b>	EC motor with digital inverter drive	
<b>Fan speeds</b>	6	
<b>Operating voltage and frequency</b>	100–125 VAC, 1 $\Phi$ , 50–60 Hz 200–240 VAC, 1 $\Phi$ , 50–60 Hz	
<b>IP rating</b>	X2	
<b>RPM (min/max)</b>	35/202 RPM	
<b>Amps (min/max)</b>	0.05/0.363 A	
<b>Watts (min/max)</b>	1.39/21.34 W	
<b>Controller<sup>3</sup></b>	Smartphone app; IR remote supplied	
<b>Optional light kit</b>	16 dimmable light settings	
<b>Operational temperature range</b>	32° to 104° F (0° to 40° C)	
<b>Operational humidity range</b>	20–90% non-condensing	
<b>Environment<sup>4</sup></b>	Indoor or covered outdoor use	
<b>Warranty (Residential)<sup>5</sup></b>	Motor	Limited lifetime in the US and Canada
	All other components	1 year in the US and Canada
<b>Warranty (Commercial)<sup>5</sup></b>	Motor	2 years in the US and Canada
	All other components	1 year in the US and Canada

<sup>1</sup> XX-XX indicates placeholder numbers, which vary depending on LED option, where the fan is installed, and other factors.

<sup>2</sup> The actual, precise fan weight will vary based on individual component weights and finishing.

<sup>3</sup> SenseME Technology is supported by Android™ and iPhone® or iPod® mobile digital devices. The app will unofficially run on an iPad™ in iPhone compatibility mode. All specifications are subject to change without notice.

<sup>4</sup> Certified by Intertek/ETL to UL507 damp rated applications

<sup>5</sup> Warranties vary by country. See full warranty for details.

### Accessories

#### Standard Remote



#### Haiku Wall Control



#### Optional Light Kit



#### Airfoil Finishes



Black



White

### Sensors

<b>Environmental sensors</b>	Ambient temperature, surface temperature and relative humidity
<b>Motion</b>	Passive infrared
<b>Communication radio</b>	Embedded Wi-Fi chip



**Made in USA**  
Haiku with SenseME



**HAIKU**  
BY BIG ASS SOLUTIONS

# I Series Fans

## TECHNICAL SPECIFICATIONS

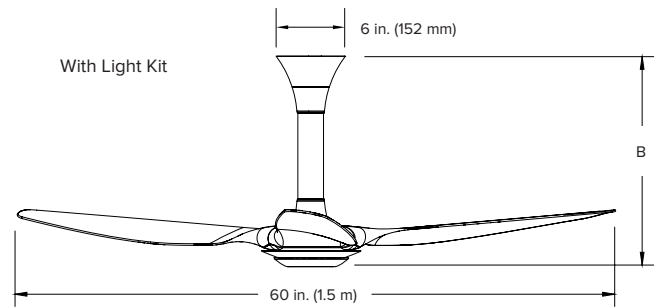
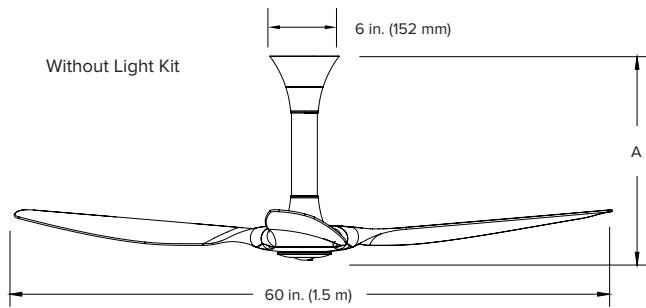

### Technical Specifications

<b>Model</b>	I Series Standard Mount	
<b>Model number<sup>1</sup></b>	K3150-A2-XX-XX-02-C	
<b>Fan diameter</b>	60 in. (1.5 m)	
<b>Fan height without light (A)</b>	16.9 in. (429 mm)	
<b>Fan height with light (B)</b>	17.4 in. (442 mm)	
<b>Hanging weight<sup>2</sup></b>	16 lb (7.3 kg)	
<b>Motor and assembly finishes</b>	Black or white	
<b>Airfoil material</b>	Glass Composite	
<b>Airfoil finishes</b>	Black or White	
<b>Number of airfoils</b>	3	
<b>Motor type</b>	EC motor with digital inverter drive	
<b>Fan speeds</b>	7	
<b>Operating voltage and frequency</b>	100–125 VAC, 1 $\Phi$ , 50–60 Hz 200–240 VAC, 1 $\Phi$ , 50–60 Hz	
<b>IP rating</b>	X2	
<b>RPM (min/max)</b>	35/202 RPM	
<b>Amps (min/max)</b>	0.05/0.363 A	
<b>Watts (min/max)</b>	2.19/31.27 W	
<b>Controller<sup>3</sup></b>	Smartphone app; IR remote supplied	
<b>Optional light kit</b>	16 dimmable light settings	
<b>Operational temperature range</b>	32° to 104° F (0° to 40° C)	
<b>Operational humidity range</b>	20–90% non-condensing	
<b>Environment<sup>4</sup></b>	Indoor or covered outdoor use	
<b>Warranty (Residential)<sup>5</sup></b>	Motor	Limited lifetime in the US and Canada
	All other components	1 year in the US and Canada
<b>Warranty (Commercial)<sup>5</sup></b>	Motor	2 years in the US and Canada
	All other components	1 year in the US and Canada

<sup>1</sup> XX-XX indicates placeholder numbers, which vary depending on LED option, where the fan is installed, and other factors.

<sup>2</sup> The actual, precise fan weight will vary based on individual component weights and finishing.

<sup>3</sup> SenseME Technology is supported by Android™ and iPhone® or iPod® mobile digital devices. The app will unofficially run on an iPad™ in iPhone compatibility mode. All specifications are subject to change without notice.

<sup>4</sup> Certified by Intertek/ETL to UL 507 damp rated applications

<sup>5</sup> Warranties vary by country. See full warranty for details.

### Accessories

#### Standard Remote



#### Haiku Wall Control



#### Optional Light Kit



#### Airfoil Finishes



Black

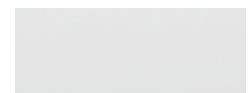

White

### Sensors

<b>Environmental sensors</b>	Ambient temperature, surface temperature and relative humidity
<b>Motion</b>	Passive infrared
<b>Communication radio</b>	Embedded Wi-Fi chip



**Made in USA**  
Haiku with SenseME



**HAIKU**  
BY BIG ASS SOLUTIONS

# I Series Fans

## TECHNICAL SPECIFICATIONS

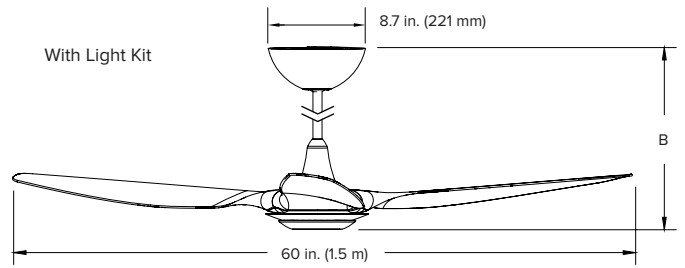
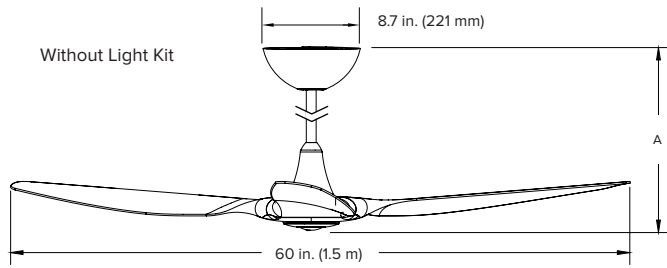

### Technical Specifications

Model	I Series Universal Mount		
Model number <sup>1</sup>	K3150-X2-XX-XX-02-C		
Extension tube length <sup>2</sup>	7 in. (178 mm)	20 in. (508 mm)	32 in. (813 mm)
Fan diameter	60 in. (1.5 m)		
Fan height without light (A)	15.7 in. (399 mm)	28.7 in. (729 mm)	40.7 in. (1034 mm)
Fan height with light (B)	16.2 in. (412 mm)	29.2 in. (742 mm)	41.2 in. (1047 mm)
Hanging weight <sup>3</sup>	15 lb (6.8 kg)		
Motor and assembly finishes	Black or white		
Airfoil material	Glass Composite		
Airfoil finishes	Black or White		
Number of airfoils	3		
Motor type	EC motor with digital inverter drive		
Fan speeds	7		
Operating voltage and frequency	100–125 VAC, 1 Φ, 50–60 Hz 200–240 VAC, 1 Φ, 50–60 Hz		
IP rating	X2		
RPM (min/max)	35/198 RPM		
Amps (min/max)	0.05/0.363 A		
Watts (min/max)	2.05/29.93 W		
Controller <sup>4</sup>	Smartphone app; IR remote supplied		
Optional light kit	16 dimmable light settings		
Operational temperature range	32° to 104° F (0° to 40° C)		
Operational humidity range	20–90% non-condensing		
Environment <sup>5</sup>	For indoor or covered outdoor use		
Warranty (Residential) <sup>6</sup>	Motor	Limited lifetime in the US and Canada	
	All other components	1 year in the US and Canada	
Warranty (Commercial) <sup>6</sup>	Motor	2 years in the US and Canada	
	All other components	1 year in the US and Canada	

### Accessories

#### Standard Remote



#### Haiku Wall Control



#### Optional Light Kit



#### Airfoil Finishes



Black

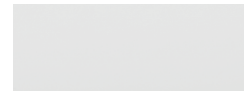

White

### Sensors

Environmental sensors	Ambient temperature, surface temperature and relative humidity
Motion	Passive infrared
Communication radio	Embedded Wi-Fi chip

<sup>1</sup> XX-XX indicates placeholder numbers, which vary depending on LED option, where the fan is installed, and other factors.

<sup>2</sup> Extended length extension tubes are available in 48 in. (1219 mm) and 60 in. (1524 mm) and are packaged separately. For taller ceilings, a Tall Ceiling Kit is also available.

<sup>3</sup> The actual, precise fan weight will vary based on actual individual component weights and finishing.

<sup>4</sup> SenseME Technology is supported by Android™ and iPhone® or iPod® mobile digital devices. The app will unofficially run on an iPad™ in iPhone compatibility mode. All specifications are subject to change without notice.

<sup>5</sup> Certified by Intertek/ETL to UL 507 damp rated applications.

<sup>6</sup> Warranties vary by country. See full warranty for details.



Made in USA  
Haiku with SenseME



HAIKU  
BY BIG ASS SOLUTIONS

Optional Accessory:

# Haiku Light Kit

## TECHNICAL SPECIFICATIONS

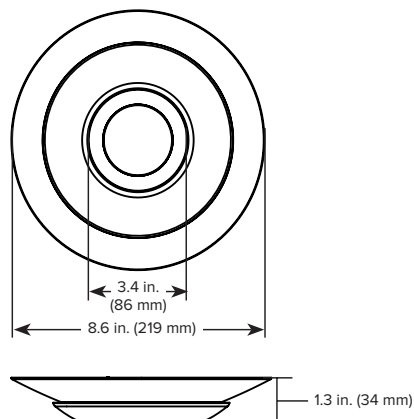

Technical Specifications	
Operating voltage	12/24 VDC
Operating current	1.5 Adc (100% PWM)
Nominal input power	16.3 W
Operating temperature	32° to 104° F (0° to 40° C)
Lens diameter	5.7 in. (145 mm)
Nominal lumen output	1280 Lm
CRI	82
Corresponding color temperature	2700 K
Dimming range	3–100%
Operating life expectancy	50,000 hours
Lens color	Diffused clear and smoky options included
Controller	On/Off control Digital dimmer
Warranty*	1 year in the US and Canada

\* 1-year warranty available in the US and Canada; certain exclusions apply. Warranties vary by country. See full warranty for details.

